

**DESCRIPTION: AIR POWERED HORN WITH COMPRESSOR**

DESCRIZIONE: AVVISATORE PNEUMATICO CON COMPRESSORE

## M4/NR

Cod.921993 (12V) 921994 (24V)

**Main specifications and performances / Principali caratteristiche**

<b>Sound pressure level / Livello sonoro</b>	<b>114 (1m)</b>		dB(A)
<b>Frequency / Frequenza</b>	<b>380</b>		Hz
<b>Nominal voltage / Voltaggio nominale</b>	<b>12</b>	<b>24</b>	Vdc
<b>Voltage range / Voltaggio di utilizzo</b>	<b>11,5-13,8</b>	<b>23-27,6</b>	Vdc
<b>Current consumption / Assorbimento</b>	<b>17</b>	<b>8</b>	A
<b>Operating temperature / Temp. di utilizzo</b>	<b>-30° to +80°</b>		°C
<b>Storage temperature / Temp. stoccaggio</b>	<b>-30° to +80°</b>		°C
<b>Corrosion resistance (trumpet) / Resist. alla corrosione tromba</b>	<b>&gt; 600 (salt spray test)</b>		Hours
<b>Operating relative humidity / Umidità di esercizio</b>	<b>30 to 80</b>		%
<b>Durability (1 sec ON, 4 sec OFF) / Durata</b>	<b>&gt;50 000</b>		Cycles
<b>Continuous blowing</b>	<b>&gt;3</b>		min
<b>Electrical insulation / Isolamento elettrico</b>	<b>500</b>		Vdc
<b>Vibration (30 min, 3 axis) / Vibrazioni</b>	<b>1</b>		g
<b>Weight / Peso</b>	<b>1250</b>		gr
<b>Main materials compressor / Principali materiali compressore</b>	Steel, Aluminium, ABS		
<b>Main materials trumpet / Principali materiali trombe</b>	Stainless steel		
<b>Main applications / Principali applicazioni</b>	Boats		

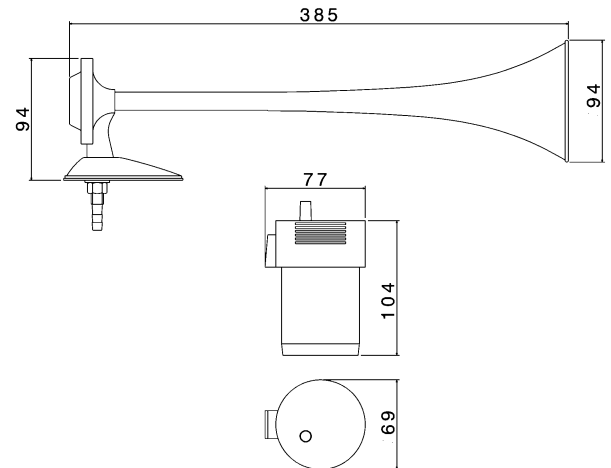
**Dimensions (mm) / Dimensioni (mm)**

**Available Electrical Connection / Connessioni elettriche disponibili**

Two Terminals 6,3x0,8 mm / 2 Spine 6,3x0,8 mm

**Other specifications / Ulteriori specifiche**

**Mechanical connection:** fix the trumpets on a rigid surface. Install the compressor on a rigid surface in a ventilated position

**Montaggio meccanico:** fissare la tromba a una superficie rigida. Fissare il compressore a una superficie rigida in una posizione ventilata.

**Horn's Protection:** choose an installation area protected from mud splash

**Protezione:** installare al riparo da spruzzi di fango.

**Packaging:** Color box 110 x 135 x h480mm

**Imballo:** scatola cartone 110x135xh480 mm

**Master carton:** 6 pieces

**Imballo multiplo:** cartone da 6 pezzi

**Conformity to Standards of / Conformità agli Standard**
**PRODUCT  
PRODOTTO**
**MANUFACTURING  
PRODUZIONE**

- ✓ ISO/TS 16949
- ✓ ISO 9001
- ✓ ISO 14001

**Product and packaging / Prodotto e confezione**
